

Successful PCDF PROTEIN Mission in ISS after Meticulous Preparation and On-the-fly Flexibility

L. De Smet¹ and S. Klai²
Space Applications Services, Belgium

K. Decanniere³
Structural Biology Brussels, Flanders Interuniversity Institute for Biotechnology, Vrije Universiteit Brussel, Belgium

and

E. Haumont⁴
Belgian Institute for Space Aeronomy (IASB/BIRA), Belgium

The Belgian User Support and Operations Centre (B.USOC) was responsible for the preparations and in-flight operations of the PCDF PROTEIN Mission that took place in ISS during four months in the first half of 2009. The Protein Crystallisation Diagnostics Facility (PCDF) allowed in-situ observation of nucleation and crystal growth behaviour of protein crystallisation experiments in microgravity. Therefore, incoming data could be analysed on-the-fly which permitted to modify the experiment in near-real-time. To achieve this experimental and operational flexibility, extensive preparation was needed. This paper reports on the various preparation and in-flight activities performed by the B.USOC operators and the PCDF science team that led to the successful PCDF PROTEIN Mission accomplishment.

I. Introduction

PROTEIN crystals play an important role in several disciplines: in fundamental research such as X-ray or neutron crystallography aiming at determining the proteins three-dimensional atomic structure, in the creation of protein-based medicines such as insulin or in industrial processes such as the food industry. The crystals require very specific properties to be used in those various applications. Unfortunately, precise control of the crystallisation process can be challenging, even for well-known model systems, making it hard to produce and reproduce crystals with the required properties. The PCDF PROTEIN experiment specifically aimed at understanding how the conditions in which crystals are grown affect these properties, including size and crystalline quality.

Protein crystals grow from a supersaturated solution. First, a sufficient number of protein molecules need to come together to form a nucleus. If this nucleus reaches a critical size, it starts growing by arrangement of protein molecules into a lattice, resulting in a macromolecular crystal with pronounced edges and faces. Growth stops when there are too many imperfections on the crystal surface or when there are not enough protein molecules left in the solution.

During growth, the crystal absorbs molecules from the solution around it, creating a lower protein concentration around the growing crystal with respect to the bulk of the solution. This zone is called the depletion zone and indicates a mass density gradient. On Earth, gravity will cause convection destroying the concentration gradient,

¹ Operations Engineer, Operations Group, Leuvensesteenweg 325, B-1932 Zaventem, Belgium, not an AIAA member.

² Operations Engineer, Operations Group, Leuvensesteenweg 325, B-1932 Zaventem, Belgium, not an AIAA member.

³ PCDF Lead Scientist, Protein Crystallization Group, Pleinlaan 2, Gebouw E, B-1050 Brussel, not an AIAA member.

⁴ PCDF Science Coordinator, B.USOC, Ringlaan 3, B-1180 Brussel, Belgium, not an AIAA member.

whereas in microgravity the depletion zone is left undisturbed as there is no convection. The net result is more pure and bigger crystals. In addition, growth in microgravity allows focusing on non-convection-related processes that occur during crystal growth.

Observation of the depletion zone in itself and a separation of convection-related and non-convection-related processes determining crystal quality shall lead to better understanding and control of crystallisation, leading to improved crystals even when grown on Earth.

Observation of the crystals themselves is also different: crystals are denser than the liquid and will sink when grown on Earth, whereas they should stay where they are in microgravity.

II. Experimental Set-up

The PCDF facility consists of two parts: the Electronics Unit, containing the electronics to control the experiment and the Process Unit containing the reactors with protein samples and diagnostics. Both units are installed in the European Drawer Rack (EDR) in the Columbus module of the ISS. A picture of the PCDF facility mounted in the EDR Engineering Model located at the Erasmus USOC in Noordwijk, The Netherlands, is shown in Fig. 1.

The PCDF instrument is split in two parts for two reasons: limiting the mass of the payload to be transferred to the ISS and back, and the need for electric power during up- and download. The latter is explained by the fact that the proteins, contained in the Process Unit, need to be continuously temperature controlled, including during the ascent and descent phase. The Process Unit is therefore designed as a standard locker insert to fit in the Shuttle's middeck lockers and in the EDR lockers. Additionally, when a mission is finished, only the Process Unit needs to be brought back to Earth and launched to the ISS with new proteins. The Electronics Unit can stay in orbit for several years.

The Process Unit can accommodate four experiment assemblies each containing individual protein samples. Once installed in EDR, experimental settings such as temperature can be modified separately and each reactor can be observed with several diagnostics tools. The diagnostics on-board of the PCDF are mounted on the camera drive and consist of dynamic light scattering (DLS) optics, a wide field of view (WFOV) camera, a microscope and a Mach-Zehnder-Interferometer (MZI). The camera drive is used to move the optics into the correct position for observation. At any time only one diagnostic can be used to observe one specific reactor. Only two of the four positions can be observed with MZI. Apart from controlling the experiment, the Electronics Unit provides the data interface to ground – via EDR, Columbus and ISS. The images taken by the WFOV camera, microscope or MZI are transferred to the Video Management Unit (VMU) of the EDR where it is possible to store them and transfer them to ground through the high rate data downlink channel of the ISS. The Electronics Unit can control the experiment through direct commands sent by the operator or through an on-board script.

An experiment assembly consists of the protein reactor and the experiment box. The protein reactor is made of synthetic quartz glass and contains the protein solution. Apart from the main volume of the reactor where the protein

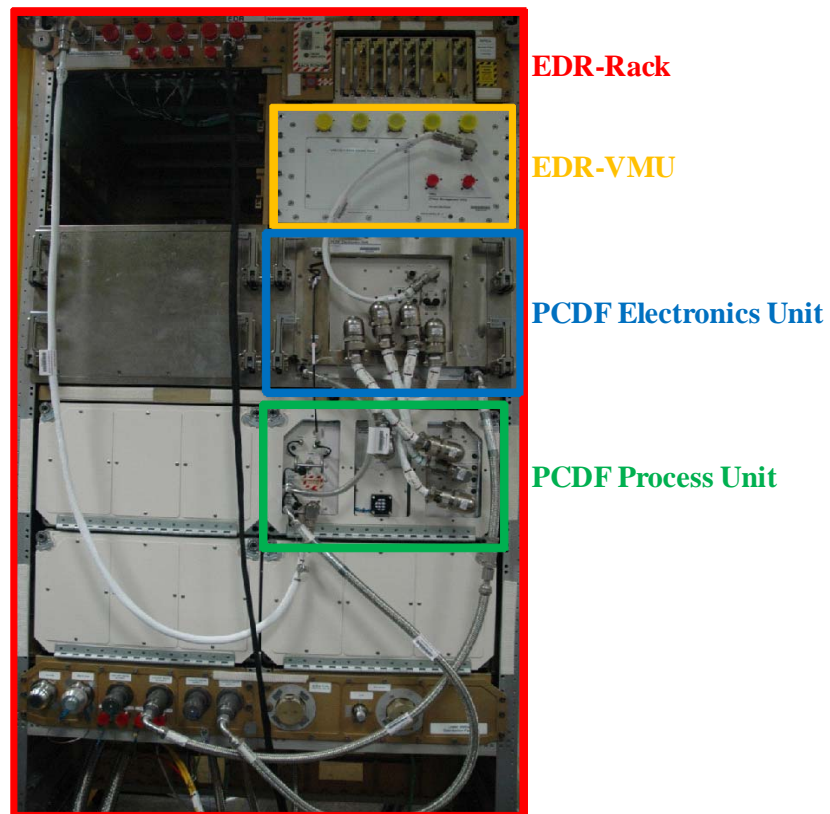

Figure 1. The PCDF facility mounted in the EDR rack (Engineering model at Erasmus USOC).

solution to be investigated is contained, the reactor has two additional volumes which can contain additional protein solution or precipitant which can be injected in the protein volume. The amount of injected liquid and the timing are defined by the science team according to experiment design parameters. The experiment box is composed of a housing with insulation foam and windows for observation, LEDs for illumination of the reactor, a Peltier element and temperature sensor for the thermal control, a stirrer to mix the protein solution, an injector piston to inject solution and the electrical interface.

More detailed information on the PCDF design can be found in Ref. 1 and 2.

III. Operational Concept

The Electronics Unit was installed in EDR on ground and was launched together with the European Columbus module during the 1E mission (STS-122) in February 2008. The Process Unit was launched on the 15A flight with Space Shuttle Discovery (STS-119). It was retrieved from the Shuttle Middeck, transferred to and mounted inside EDR by Japanese astronaut Koichi Wakata. After being connected with the Electronics Unit and with EDR for data and power resources, ground activities started until the de-installation of the Process Unit during the 2J/A mission (STS-127) in July 2009. Koichi Wakata transferred it back to Space Shuttle Endeavour, returning the space-grown crystals back to Earth for further investigation by the science team.

Two of the four reactors installed in the PCDF Process Chamber were dedicated to the study of nucleation, whereas the other two were used to investigate the crystal growth process. With PCDF the science team has the possibility to inject protein solution or precipitant, to vary the temperature between 4 and 40 degrees Celsius, and to stir the central reactor volume. Therefore, if experiments are designed accordingly, grown crystals can be dissolved and the experiment can be started over for a new crystallisation cycle. This technique improves phase diagram coverage and data redundancy. For the reactors dealing with nucleation, 6 cycles of about 2.5 days were executed, while the growth cycles lasted for about 8 days and only 4 cycles were planned for each reactor. For each of the reactors, the crystals grown in the last cycle were not dissolved, but returned to Earth for post-flight analysis. A picture from the post-flight inspection of the space-grown crystals in reactor two is depicted in Fig. 2.

Apart from the installation and de-installation which were performed by the crew, all PCDF activities were controlled from the B.USOC either using direct commands from the operator or by uplinking and activating an on-board script. The latter is called Command Sequence Table (CST) and is a text file which contains Tool Command Language (TCL) statements or PCDF Control Language (PCL) commands to be executed by the PCDF software. A CST is uplinked from ground via a series of telecommands and only one CST at a time can be saved in the PCDF memory. A CST can be started, stopped, paused and resumed from ground.

All low and medium rate telemetry from PCDF arrived at B.USOC through a cascaded link from Erasmus USOC through CD-MCS (Columbus Decentralized Monitoring and Control System). Erasmus USOC for its part received the data from the Columbus Control Centre (Col-CC). All data were stored in the B.USOC and its Dutch counterpart Erasmus USOC High Rate Data Processor (HRDP) archive. Both real-time and archived telemetry were accessible to the science team and Payload Engineering Support (PES) via the User Home Base (UHB) concept, where the telemetry distribution is done through a USOC developed software called YaMCS via a secured VPN connection. YaMCS allows to receive the real-time telemetry (limited according to the specific data access rights of the user), or to independently perform a custom telemetry replay from the HRDP archive. Moreover, it allows dumping specific telemetry items to a file for further analysis. The raw images produced by PCDF arrived at Erasmus USOC and were automatically forwarded to a dedicated folder on a B.USOC shared hard disk, accessible to all involved parties. The raw images were converted into the viewable PNG format at B.USOC and were stored in the same folder. Commanding PCDF was not allowed from the UHB, this was only possible from the B.USOC.

The operational objective of the PCDF PROTEIN mission was to adapt the scientific conditions in almost real-time based on on-the-fly analysis of incoming data. This required a specific near-real-time interaction between the operators and the science team, each monitoring the experiments from their viewpoint.

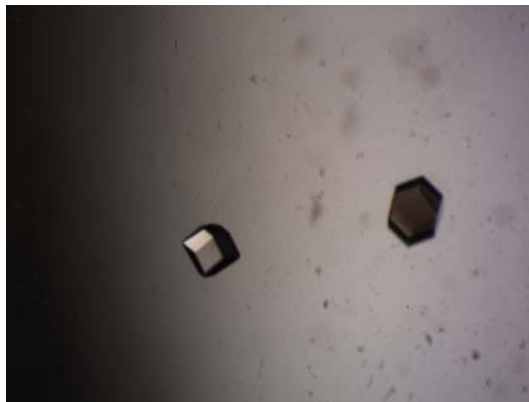

Figure 2. Crystals from experiment box 2 (post-flight picture). The size of the crystals is around 0.2 mm.

Additionally, the PCDF PROTEIN experiment involved many parties around the world: the PCDF science team, mainly located in Granada (Spain) and Brussel (Belgium); the operators at the B.USOC in Brussel (Belgium) responsible for PCDF, at the Erasmus USOC in Noordwijk (The Netherlands) responsible for EDR, at Col-CC in München (Germany), at MARS USOC in Napoli (Italy), and at HOSC in Huntsville (United States); the Payload Developers (PD), Payload Integration Managers (PIM), and Payload Engineering Support (PES) located at EADS Astrium in Friedrichshafen (Germany) for PCDF and at Alenia SIA in Torino (Italy) for EDR; and last but not least the ESA Payload Operations Managers (ESA-POM) and ESA Mission Science Office (ESA-MSO) at ESTEC in Noordwijk (The Netherlands). The good coordination between all the teams during the preparation and in-flight periods was another challenge.

IV. Preparation

This part concentrates on the various preparation activities performed by the B.USOC operators and the science team to achieve a successful mission.

A. Flow used for PCDF

Fig. 3 depicts a general overview of the activity flow used to prepare the PCDF PROTEIN mission. The figure has to be interpreted as follows: items in oval boxes are operational products whereas items in rectangular boxes are activities. Items on the left side of the figure show the interfaces with other partners. As can be seen, the preparation was an iterative process. This subsection gives an overview of the big flow from box to box as depicted in the figure, whereas the following subsections give detailed information on all the activities and their influence on the operational products.

Based on the (final) design of the instrument and the requirements of the science team stated in the Experiment Scientific Requirements (ESR), the initial planning inputs, procedures, displays and ground system could be prepared. With those initial products, the iterative process started. Several activities such as Mission Data Base validation, crew training and science runs were performed during which the operational products needed to be evaluated and updated when necessary. At a certain moment in this process, it became clear which flight rules, payload regulations, ground PODFs (Payload Operations Data File) and resources were needed for a good completion of the mission. Some months before the launch of the Process Unit, the Experiment Sequence Test (EST) was performed. During and after the EST execution, it became clear which operational products needed to be fine-tuned. Last but not least a mission calendar was prepared.

It is evident that during the whole process close contact was required with the science team, the PIM, and the Erasmus USOC. Additionally, all other parties needed to be kept up to date on the status and upcoming plans or activities.

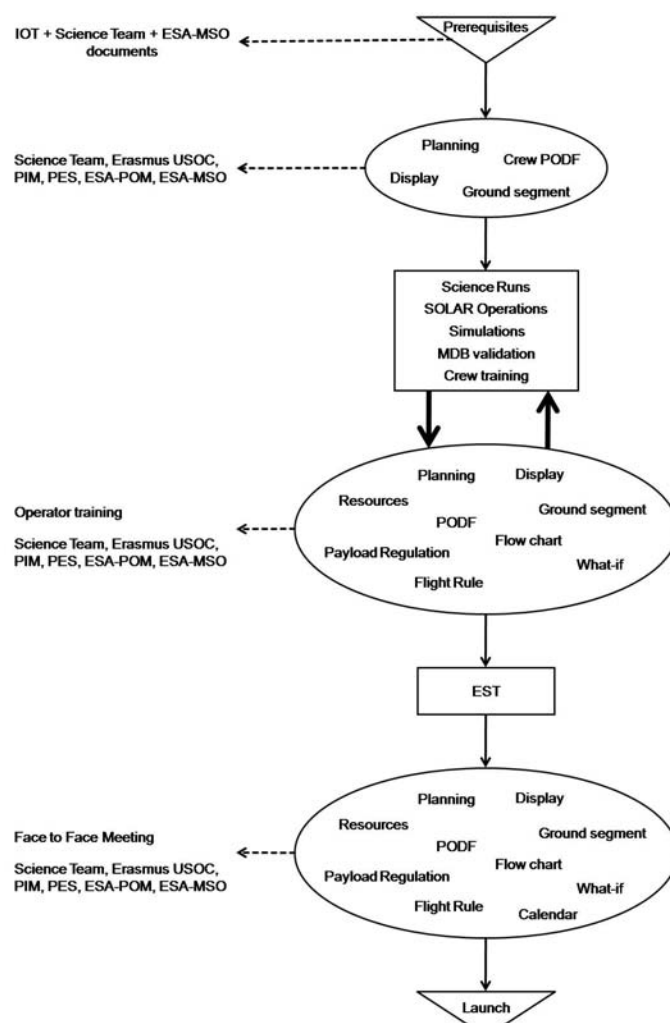

Figure 3. Overview of activity flow during the PCDF PROTEIN mission preparation.

B. The Importance of Science Runs

There were three types of “PCDF-like” instruments available to the science team to prepare the PCDF PROTEIN mission. The Engineering Model (EM), the Science Reference Model (SRM) and the Lab Model (LM). The EM is almost identical to the PCDF Flight Model (FM) and can be used inside the EDR EM installed at Erasmus USOC or integrated in the B.USOC ground support equipment. The SRM is hosted at the B.USOC and contains a process chamber with optics comparable to the flight model, but without the PCDF flight software. Other soft- and hardware are used to command and monitor the SRM. The LM is hosted in Granada, is comparable with the SRM, but can contain only one experiment assembly instead of four.

As protein crystallisation experiments are very sensitive to geometry, size and materials of the reactor, experimental conditions had to be adjusted for use in PCDF reactors, and the SRM and LM instruments were used for these preparations. However, there are significant differences between the SRM/LM and the EM software, in particular with respect to automated operations. Also, the SRM and LM are hands-on instruments run by the science team with support from the B.USOC Science Coordinator, whereas the PCDF Flight hardware can only be operated by authorized operators using flight-like procedures. It was therefore vital to validate experiment flow and timing, CSTs, contingency management and communication procedures between science and operator teams using the PCDF EM in a realistic setting. This was done during the science runs. In addition, the science runs produced reference data needed to develop and test the on-the-fly “Science Monitoring Tools” developed by the science team.

For the operators, the science runs were in the first place intended to get acquainted with the PCDF features and to test, set-up, and fine-tune the science flow. Science runs with the EM were executed with the B.USOC ground support equipment and involved the B.USOC operators in close collaboration with PD and PES from Astrium. The science team filled the reactors and the experiment assemblies were mounted in the PCDF Process Chamber by PD. After installation and activation, a science run could start with PCDF commands sent by the operators. Even in this early stage, the UHB allowed scientists to follow the incoming data live and to replay and download data. The PES possessed a UHB as well, making it much easier to answer questions from the operators and to redirect them during or after an anomaly. The science runs on the EM turned out to be very useful for the operators because next to the general hands-on payload familiarization, they were used for procedure preparation and validation, and CST testing and validation.

During the preparation of the PCDF PROTEIN mission, four science runs were performed on the EM. The first one started in August 2007 and the last one ended in September 2008. They lasted between one and three months with quiet periods in between used for evaluation, repairs and refurbishment.

Already from the first science run some problems rose needing a workaround, an example is the use of time-tagged commands in CSTs. PCDF allows for time-tagged commands and direct commands. During the science runs it became clear that using the time-tagging feature was not straightforward, as those commands were not always executed on the desired and expected time and sometimes they were even skipped. The science team had to revise their initial approach of using exact command timings by using a relative timing instead.

Another unexpected problem was that positioning the camera drive took much longer than originally predicted. This led to the unfortunate loss of parallel observation. PCDF was supposed to be able to observe the nucleation and crystal growth behaviour in the four experiment assemblies in parallel. However, during the science runs it became clear that it takes too much time to move the camera to the different positions and the science team concluded to concentrate on only one reactor at a time. This had of course a big impact on the science planning as less time became available per reactor. The science team came up with a new plan where science priorities had to be taken into account, and confirmed that the Experiment Science Requirements could still be met.

The science runs were the most appropriate activities for the operators to test and get acquainted with the mission data base of PCDF and with the instrument behaviour during and after execution of the commands. Additionally, the operators and the science team could develop a familiarity for the science impact of the commands. This gave the operators the knowledge to properly accommodate the telemetry displays to the needs specific to the experiments planned for the mission. Moreover, the operator and science team started to understand how to operate PCDF efficiently and the operators started to understand how to translate the wishes of the science team into commands or CST updates. This knowledge was used to develop handy ground PODFs.

Another operational product was based on the experience from a science run, namely the PCDF PROTEIN thermal clock flight rule. The PCDF Process Unit was to be powered in the Shuttle Middeck during the launch and until the transfer to EDR to keep the reactors inside at a predefined temperature with monitoring. Only when the PCDF Process Unit is powered it controls and records the temperature of the Process Chamber. During the transfer to and installation in EDR, the PCDF Process Unit was – obviously – unpowered and this unpowered time needed to

be as short as possible. Therefore during one of the science runs, a test was performed to characterise the thermal behaviour of the PCDF Process Unit and to define a thermal clock for the unpowered period. Together with the science team, the flight rule describing the power constraints was drafted. This was a delicate and difficult process, since the flight rule had to reflect that a thermal clock for power down was defined, but that even when the thermal clock was exceeded, installation should go on unless something was really preventing the activation in EDR, where thermal control should then be reassured in the Shuttle Middeck. The reason was that, for the protein samples selected for this mission, exceeding the thermal clock for a short period would have significant effects on experiments and quality of the data obtained, but samples should not be considered lost as scientifically relevant experiments would still be possible. In addition, proper assessment of sample degradation depended on a diagnostic provided by the PCDF instrument itself (DLS instrument). Obviously, a lot of discussions and time went by before establishing the correct wording and rules to clarify this to the operational community.

The science runs on the EM resulted in operators and science team getting acquainted with the PCDF commands and execution; writing and validation of clever ground PODFs; optimized CSTs; creation of the power constraint flight rule and last but not least, an optimal cooperation between the operators and the science team as well as between operators and the PCDF PES was established.

C. Experiment Sequence Test

The Experiment Sequence Test (EST) is an end-to-end test performing a complete experiment sequence using the flight-like operations set-up and all operational products. It is a pre-requisite for the execution of ESA sponsored experiments on-board the ISS. The PCDF EST was set up as a full dry run of the operations for one experiment cycle of the mission. Although the dissolution and execution of a following cycle are part of the on-orbit experiment flow, only one science cycle was performed during the EST which lasted for about one month – mid October till mid November 2008. The EST is nevertheless valid as the EST is meant to test mainly the operations part by exercising the main experiment sequences. For PCDF each experiment cycle needs the same PODFs and similar CST's, which would have made the complete exercise merely a repetitive one. The EST involved the B.USOC, the Erasmus USOC, PCDF PES and PIM, and the science team.

Prior to the EST an operator training was provided to give an overview of the latest status of the operational products, to rehearse the complete flow and the instrument behaviour, and to explain the science objectives.

As per EST requirements, and different from the science runs, the PCDF EM was installed in the EDR EM at Erasmus USOC. In this configuration it was discovered that packet loss occurred between the PCDF and EDR. Especially the CST uplink faced difficulties. The software and related ground PODF were updated so that the uplink could be resumed where it was stuck. Additionally, a test on the FM – already on orbit – was executed at the end of December 2008. The PCDF Electronics Unit was powered on and a CST was uplinked. From this test it was clear that the packet loss only occurred on ground with the EM.

CST execution during the EST revealed some minor anomalies which were analysed and understood. All CSTs were updated accordingly after the EST and were declared ready for flight execution. After the EST, the science team changed a bit the way of handling the different temperature controls of the experiment boxes in the CST, opting for more complicated temperature profiles, which caused a real challenge for keeping the automatic recovery plan up-to-date. After some testing on the EM, a solution was found and a plan was drawn using tested and approved procedures.

Not all telemetry received at Erasmus USOC during the EST arrived at the B.USOC and a replay was not possible. For the flight, the science team needed to access the data almost real-time, so this ground problem was resolved before the start of the PCDF PROTEIN mission.

At the start of the EST, several routine activities were planned to be executed daily on a fixed pre-defined time, just like it would be for the on-orbit execution: two times a day a real time command window of 10 minutes (for the on-orbit activities, four windows would be scheduled), twice a day an opportunity to uplink a CST and once a day a PCDF internal table handling. It was shown that only 28% of the fixed activities were used during the EST, but more importantly there was the need to shift the planned activities to meet the requests of the science team. This showed the need for the – already requested, but not yet approved – 24/7 real-time command window to obtain a full flexibility and optimise the science activities. This EST result convinced the community to approve the 24/7 real-time command window during the complete PCDF PROTEIN mission. Another requirement arising from the desire to react on-the-fly was the availability of a 24/7 downlink not only for low and medium rate, but also for high rate data. The continuous high rate data downlink of 2 megabit per second was not straightforward to obtain, but was secured before the start of the mission.

For the science team, the EST provided an opportunity to validate the reactor filling and transport procedures. During the EST itself, initial data showed the need for more frequent image taking than previously anticipated. In

this way, there is always a recent image available giving an overview of the reactor in case of anomalies or doubts. A few minor anomalies indicated the need for relaxing the timing of the experiments, especially with respect to injections. Most importantly, the EST confirmed the need for constant fine tuning of experimental conditions during the flight, and therefore the need for a 24/7 real-time command window. Finally, in view of the bandwidth problems encountered for transfer between B.USOC and the UHB's, a backup data path was developed where data was transferred via a VPN-secured link from HRDP to the Brussel UHB and then forwarded using ssh-encrypted transfer over standard internet connections to the Granada UHB.

D. Simulations

In preparation of the PCDF PROTEIN mission and as part of the training of the Operations Teams, several kinds of simulations were performed: stand-alone simulations, European simulations, and Joint Multi Segment Trainings (JMST). Most of the simulations concentrated on the PCDF activation and de-activation activities as the science part was difficult to simulate and above all, the science part was thoroughly tested for real during the science runs.

The stand-alone simulations were set up between the B.USOC and the Erasmus USOC only and were used to set up, train and fine-tune the PCDF activation and de-activation flow. Those were the critical, unpowered periods requiring a good interaction and understanding between the operators of both USOCs.

During the JMSTs, the Shuttle Operations Coordinator (SOC) of NASA was involved. Those simulations proved to be very useful to coordinate the several what-if scenarios that could occur during the Shuttle period (from launch until transfer to Columbus and back). Through the questions during the simulation, a lot of off-nominal scenarios were passed through and written down. Additionally, the need for a 'voice loop coordination' sheet was drawn up for the PCDF activation and de-activation. In this way, it was clear for everybody who would contact who at which stage of the flow.

E. Operational Experience gained from SOLAR Operations

The SOLAR external payload is a European payload installed on the Columbus External Payload Facility (CEPF). SOLAR is dedicated to tracking and observing the Sun and hosts three instruments: SolACES, SOLSPEC and SOVIM. The payload was launched together with the European Columbus laboratory on the 1E flight (STS-122) in February 2008, and has been operating since that moment. The characteristics of the SOLAR payload and its operation are further explained in the AIAA SpaceOps 2010 paper "SOLAR Payload Operations: Achieving Flexibility to Support a Long Term Science Mission" (Ref. 3).

The SOLAR operators are the same ones as for the PCDF PROTEIN mission. This gave them one year of real-time Columbus-ISS operations experience which undeniably led to a thorough understanding of the complexity and different requirements of executing a scientific experiment on-board the ISS and inside Columbus. This contributed to an efficient and clever preparation of the PCDF operational products. A thorough and in depth description of the operational constraints and their consequences when operating a (external) payload on Columbus-ISS is given in the AIAA SpaceOps 2010 paper "Dealing with Operations Constraints for External Payloads on ISS" (Ref. 4).

The most significant preparation based on the SOLAR experience was the set up of an automatic recovery plan in case PCDF would reboot spontaneously. As SOLAR from time to time experiences this kind of unwanted reboots, a plan to recover PCDF as soon as possible was developed in case this would happen with PCDF as well. When PCDF would reboot, it is important that temperature control for the individual reactors is restored and that the correct temperature is reached as soon as possible. As a reboot can happen during a Loss Of Signal (LOS) period, a fully automatic recovery method was devised.

Furthermore, several PODFs were created keeping experience and established style and tradition from SOLAR operations in mind. Together with the knowledge gained during the science runs, one long science PODF, including cross references where needed, was created which should be sufficient to execute all the scientific requests.

For SOLAR, a daily operations report (DOR) is sent to the different parties involved. It contains information about the last day, about anomalies, about the archive integrity and it provides an overview of the upcoming activities. Due to the limited duration of the PCDF PROTEIN mission and the subsequently dense schedule, it was important to create a tool that covered more than what is usually provided in the DOR. The impact of ISS vehicle traffic, periods of less favorable microgravity conditions, anomalies, unexpected experiment behaviour, reshuffling of science cycles etc, on the overall mission should be available. Therefore together with the ESA Mission Science Office, a PCDF calendar was designed, providing all necessary information for all involved parties.

F. Other Activities

Some weeks before the start of the mission, a face to face meeting was held with the B.USOC, the Erasmus USOC, the PCDF responsables of the FCT team, and the ESA Payload Operations Managers. All operational steps

were discussed in detail and the way of executing science was explained. During the face to face meeting the need to create an additional backup for the images by saving them on the EDR VMU was envisaged. The reason behind was that the continuous and real-time downlink of the PCDF images could not be tested before the start of the PCDF PROTEIN mission. In this improved procedure all images are also saved on-orbit in the EDR VMU and could be replayed and downlinked during a period when PCDF would not generate images. This led to a considerable change in the operations plan and products, but was well worth the effort.

Last but not least, an operational what-if table was prepared for the installation and de-installation activities so that everybody was prepared for every possible anomaly. Additionally, together with the science team and the ESA Mission Science Office, a what-if table was prepared for every possible anomaly affecting the science objectives.

V. On-orbit Execution

In general, the operational on-orbit execution of the PCDF PROTEIN mission went almost perfect: all CSTs were executed successfully, the ground PODFs showed to be very flexible and useful, the telemetry and imagery archives are almost complete, and the insight of the working of the PCDF instrument was optimal. This part covers mainly the activities which were not foreseen to occur during the mission, but which were most of the times quickly resolved thanks to the extensive preparation.

The on-orbit execution phase started with the launch of STS-119 on March 15, 2009. The PCDF Process Unit was continuously powered inside one of the Middeck lockers of Shuttle Discovery until March 20, when PCDF Process Unit was transferred to and installed in EDR by Koichi Wakata and re-activated by the Erasmus USOC shortly after. All activities were performed smoothly and successfully, except one: the PCDF fiber optics cable was not correctly installed. This occurred as well during preparatory activities on the EM, and therefore the operators were prepared to instruct the crew how to properly align the cable. After two trials, the cable was properly aligned and the DLS data signal transmission was fine.

The automatic uplink of the CSTs was interrupted every now and then by micro LOS. Thanks to the update of the ground software and related ground PODF during the EST packet loss problems, the uplink could be resumed where it was stuck. Although no packet loss occurred during the on-orbit execution, the established workaround showed to be very useful during the unpredictable micro LOS periods.

To support the interpretation of the science results for PCDF, microgravity measurements can play an important role. The closer the measurements are performed to the PCDF instrument the better the interpretation. Therefore the Microgravity Measurement Assembly (MMA) equipment of the Fluid Science Lab (FSL) in the Columbus module is suitable. This was discussed several times before the start of the mission, but unfortunately no FSL activities were planned. The main issue is that for activating FSL, another USOC, MARS USOC hosted in Napoli, needed to staff the console which posed significant constraints on the running activities and available resources at the MARS Center. In the beginning of the mission, the science team and the ESA Payload Operations Manager agreed to activate FSL only during the first 24 hours of every PCDF growth cycle where microgravity measurements showed to be most important for the science team. However, due to the flexible and on-the-fly operation of the PCDF experiment, an early planning of this FSL activity was not that straightforward. Due to science changes or science interruptions during anomalies, the start of a new cycle could be postponed or moved forward. The daily updated PCDF calendar proved to be of great value: both the European Planning Team and the operators at MARS USOC used it to know the upcoming PCDF plans. In addition to the FSL MMA measurements, accelerometer data from the SAMS/MAMS equipment covering almost the complete month of June became available to the science team.

Almost two weeks after its activation, the first PCDF unexpected reboot occurred. The prepared automatic recovery plan was put into action and proved to work to preserve the correct temperature control. It is evident that the science was interrupted due to the necessity to uplink an updated CST. Most of the times the experiment cycle could be continued instead of restarted, limiting the science impact. During the 4 months of on-orbit operations, PCDF rebooted 13 times. Up to now, no reason has been found for this unwanted behaviour of PCDF.

Roughly two weeks after the first unexpected PCDF reboot, PCDF was suddenly powered off due to an EDR ESEM board failure. This ESEM board powers both PCDF Electronics Unit and PCDF Process Unit. The only way to put EDR and PCDF back to a nominal situation was to power cycle EDR. This recovery mostly took several hours, during which the active temperature control was lost and the experiment cycles had to restart from scratch. Therefore the science impact was considerably high. After three re-occurrences and some investigation, it was decided to replace the failing ESEM board. The crew exchanged the board 45 days after the first failure. During the re-activation of PCDF after the ESEM board replacement, an untested combination of PCDF Electronics and Process Unit power-ups resulted in a very fast cooling of the Process Chamber temperature. Fortunately, the

temperature control could be recovered fairly quickly. Until now the influence on the experiment is not known. After the board replacement, no ESEM board failures occurred anymore.

As agreed just before the mission, all images would be recorded on the EDR VMU together with the real time downlink. Roughly halfway the mission, the VMU hard disk was full because the CSTs produced more images than originally foreseen. As some images were missing or incomplete, all VMU records were replayed completing the image archive as best as possible before erasing the full disk. Just before the end of the mission, the second part of the VMU records was replayed. Thanks to those redundancy actions, the science team possesses 99.2% of the ~42000 images taken during the entire PCDF PROTEIN mission.

Roughly one month before the end of the mission, the motor of the radial camera drive got stuck. Luckily the position allowed covering a considerable and useful part of the experiment boxes. Together with the science team it was decided to take no risk and to continue the experiment run without changing the radial motor position deferring the troubleshooting until the PCDF Process Unit was back on ground. The CSTs were adapted to not use the radial motor anymore and to limit the other camera movements as much as possible to reduce the risk of additional motor failures. Fortunately, no other motor failures occurred and imagery of the status of all experiment boxes could be obtained. The on-ground troubleshooting revealed that the shaft of the radial motor is broken due to fatigue.

Shortly before and during the entire mission a bi-weekly teleconference was held between the ESA Mission Science Office, the science team, the B.USOC, and the ESA Payload Operations Manager. When needed also a representative of the Erasmus USOC and the PCDF PIM/PES was attending the meeting. During those meetings an overview of the past activities was given and information on previous or upcoming activities influencing the PCDF science planning was provided. Together with all parties, the upcoming activities were discussed and agreed on. Those meetings proved to be very useful to keep everybody up to date and to make sure the overall science objectives were protected.

VI. Conclusion

The meticulous preparation of the PCDF PROTEIN mission ensured an almost perfect operational on-orbit execution of the PCDF PROTEIN mission. The rewards of this extensive preparation were harvested during the nominal operations as well as during anomaly containment and recovery. For the latter one, this resulted in a minimum loss of experiment execution, maximum sample protection and successful data recovery. It is shown in this paper that the enormous flexibility provided by the operators to the science team and vice versa together with the meticulous preparation are one of the most important keystones that led to the successful execution of the PCDF PROTEIN mission. It can be concluded that the general approach used for the preparation and execution of the PCDF PROTEIN mission could prove useful for similar future missions and could help facilitate increased science return.

Acknowledgments

The authors would like to thank the Erasmus USOC and MARS Center Operator teams, the ESA Payload Operations Management (ESA-POM), the ESA Mission Science Office (ESA-MSO), the Payload Engineering Support teams, the Payload Integration Manager, the Columbus Control Centre Flight Control Team (Col-CC FCT) and the Huntsville Operations Support Center (HOSC) for their collaboration and support to B.USOC.

A special word of thanks goes to the ESA USOC Management, the B.USOC Management and the Space Applications Services Management for their close cooperation and for providing the budget and personnel for the B.USOC.

The PCDF PROTEIN experiment is funded and undertaken by ESA's Directorate of Human Spaceflight (D/HSF) in the context of its European Programme for Life and Physical Science in Space (ELIPS) and by the Belgian Science Policy Office (BELSPO). B.USOC is part of the Services & Operations Division of the Belgian Institute for Space Aeronomy (BISA) and is funded through the ESA Prodex and other programs by BELSPO. B.USOC and Space Applications Services are funded by the ESA's Exploitation Programme.

References

¹Pletser, V., Bosch, R., Potthast, L., Lautenschlager, P., Kassel, R., "The Protein Crystallisation Diagnostics Facility (PCDF) on Board ESA Columbus Laboratory," *Microgravity Science and Technology*, Vol. 21, No. 3, Jul. 2009, pp. 269-277.

²Pletser, V., Minster, O., Bosch, R., Potthast, L., Stapelmann, J., "The protein crystallisation diagnostics facility: status of the ESA programme on the fundamentals of protein crystal growth," *Journal of Crystal Growth*, Vol. 232, Issue 1-4, Nov. 2001, pp. 439-449.

³Brantschen, S., Michel, A., “SOLAR Payload Operations: Achieving Flexibility to Support Long Term Science Mission,” *AIAA Journal*, (submitted for publication).

⁴Wislez, J.-M., Michel, A., “Dealing with Operations Constraints for External Payloads on ISS,” *AIAA Journal*, (submitted for publication).